

Quality Solution For All Growers



Watering Tunnel

From *K W Automation*



Simplicity and precision are the hallmarks of the new Water Tunnel, designed and manufactured by KW Automation.

Three separate spray bars are able to be used separately giving the user the ability to configure the system to meet their needs.

Being able to water and fertilise in one easy operation makes the system highly attractive.

The solenoid operated water valve, in conjunction with the electric eye sensor, allows the Watering Tunnel to only water when the tray/pots are in position. This makes for a highly cost-efficient system, especially when fertilising.

A standard mechanical variable speed drive allows to tune the speed of the conveyor to the same pace of other machines on the seeding line.

- ▶ **Delicate** spray pressure minimizes soil mix washout from each cell/pot.
- ▶ **Precise** water injection into individual tray cells if required (optional).
- ▶ **Durable** all aluminium construction.
- ▶ **Multiple** configurations with separate fertilising and fungicide spraying possible (optional).
- ▶ **Complete** - Warranty and after sales support.

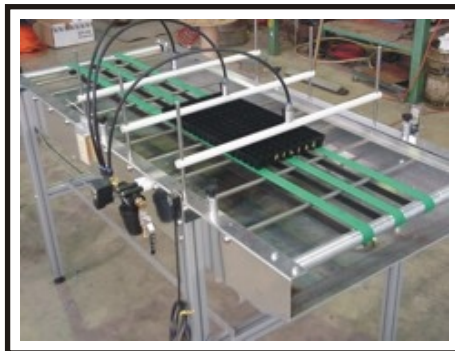

HEIGHT OPTION - POTS ONLY

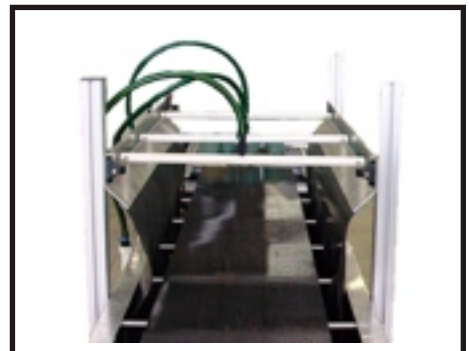

Manufactured By:

K W Automation

PO Box 121, Old Bowling Green Rd
Palmwoods, Queensland 4555 Australia
Int (61) - (07) 5445 9549 - Fax (07) 5445 0499
Web Site: www.kwautomation.com.au

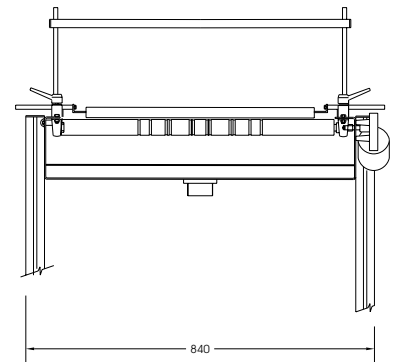
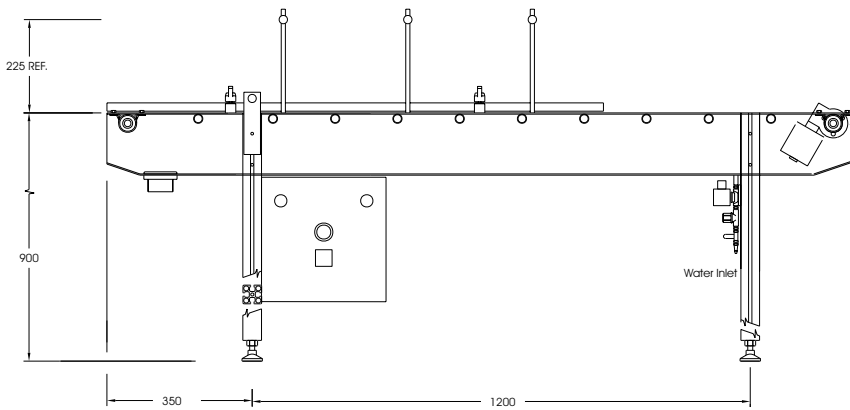
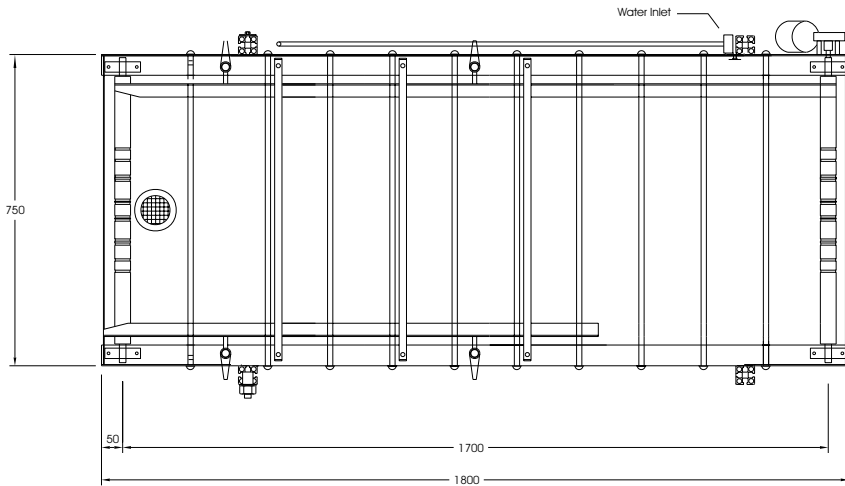

Watering Tunnel	Specifications
Maximum Tray Width	550mm (22")
Maximum Tray Length	Unlimited
Spray Bars Max. Height Adjustment	- 200mm(8")Standard
Optional	- 600mm(24")
Plug Tray/Hr Std Machine	300*
Plug Tray/Hr Midi Machine	600*
*Optional Faster Production	Available on Request
Power Supply Req'd	240V(single phase)
Length	1.800 Metres
Width	.900 Metres
Height	1.125 Metres

Please note all plans & specifications may change without further notice.