

Quality Solution For All Growers



Transplant Conveyor

From *K W Automation*



- ▶ **Long Lasting** extruded aluminium frame construction.
- ▶ **Mechanical** variable speed drive allows belt to run at required speed for operator comfort and pace of transplanting line.
- ▶ **3 Way** Adjustable tray holders.
- ▶ **Durable** P.V.C. belt for conveyor.
- ▶ **Height** adjustable legs.
- ▶ **Available** in 2,4,6 and 8 work stations.
- ▶ **Sealed** bearings for minimal maintenance.
- ▶ **Conveyor** length and number of workstations may be customised to meet owners needs.
- ▶ **Choice** of single phase (240V) or three phase (415) power.

Optional Extras:

- ▶ **Height** adjustable seats.



Manufactured By:

K W Automation

PO Box 121, Old Bowling Green Rd
Palmwoods, Queensland 4555 Australia
Int (61) - (07) 5445 9549 - Fax (07) 5445 0499
Web Site: www.kwautomation.com.au

Transplant Conveyor Specifications

Capacity of Geared Motor	.37 kW (1/2 HP)
Power Supply Req'd	240V or 415V
Length 4 Station	4000 mm
Length 6 Station	5300 mm
Length 8 Station	6800 mm
Width	900 mm
Height	900 mm
Conveyor Height	800-900mm
Max. Tray Holder Size	550 x 300mm

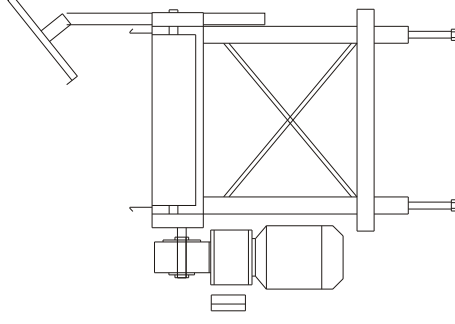
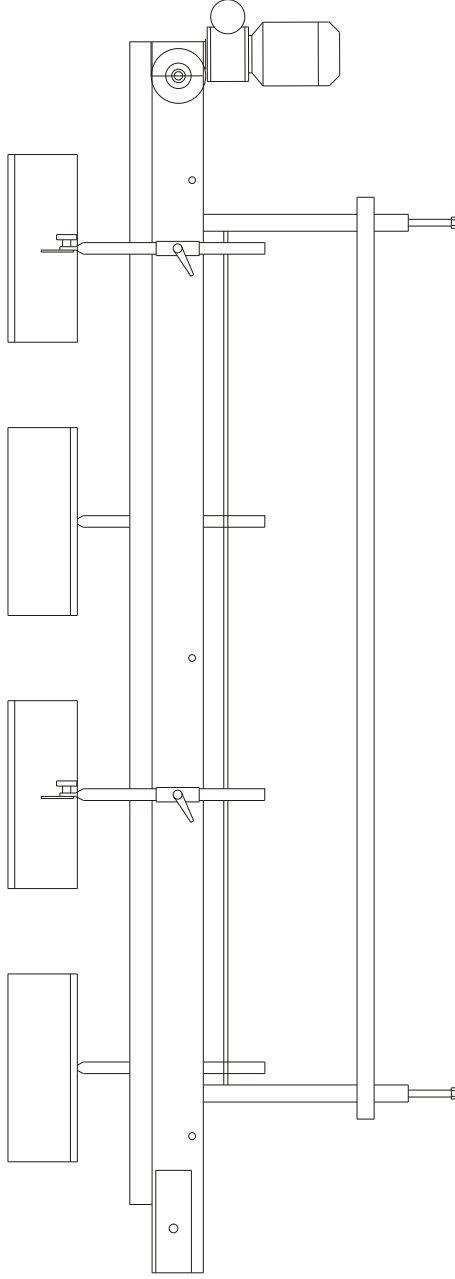
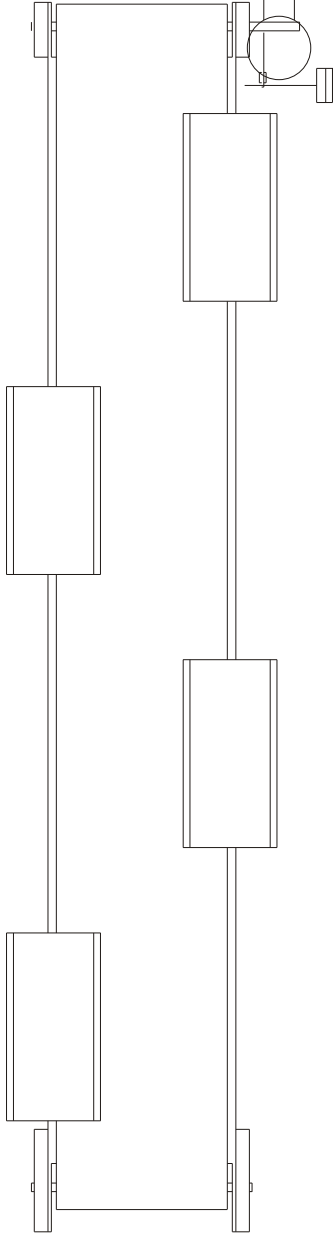

Please note all plans and specifications may change without further notice.