



# Soil Mixers

From *K W Automation*



" Assures thorough mixing of materials and fertilisers. "

Our unique mixing spiral is designed to bring all materials to the centre of the machine and assures thorough mixing of all materials and fertilisers.

Four Spirals are fitted into the mixer bowl, two lefthand and two righthand.

The outer Spirals bring the soil to the centre and the inner Spirals bring the soil to the outside.

Once the mixer is half empty the inner spiral stops agitating and the outer spiral empties the entire contents.

**Optional Extra :**

For abrasive materials a 5mm liner can be placed inside the bowl for easy replacement, and the mixing spiral can be hard faced.

Unique Mixing Spiral



- ▶ **Able** to mix any kind of potting mix in 5 - 10 minutes.
- ▶ **Mixer Bowl** made from 3mm steel plate.
- ▶ **Overload** protection.
- ▶ **Thorough** mixing.
- ▶ **Centrally** mounted sliding mixer door controls soil flow out of mixer.



**Manufactured By:**

***K W Automation***

PO Box 121, Old Bowling Green Rd  
 Palmwoods, Queensland 4555 Australia  
 Int (61) - (07) 5445 9549 - Fax (07) 5445 0499  
 Web Site: [www.kwautomation.com.au](http://www.kwautomation.com.au)

<b>1 Cu. Yard Mixer Specifications</b>	
Motor Capacity	4 H.P.
Power Supply Req'd	415V (3 phase)
Amps/Phase	6
Length	1.70 Metres
Width	1.10 Metres
Height	1.85 Metres
Starter	D.O.L.

<b>2 Cu. Yard Mixer Specifications</b>	
Motor Capacity	10 H.P.
Power Supply Req'd	415V (3 phase)
Amps/Phase	14
Length	2.80 Metres
Width	1.15 Metres
Height	2.35 Metres
Starter	Star Delta

\* Includes spill chute

<b>1 Cu. Metre Mixer Specifications</b>	
Motor Capacity	7.5 H.P.
Power Supply Req'd	415V (3 phase)
Amps/Phase	11
Length	2.25 Metres
Width	1.10 Metres
Height	1.85 Metres
Starter	Star Delta

<b>2 Cu. Metre Mixer Specifications</b>	
Motor Capacity	15 H.P.
Power Supply Req'd	415V (3 phase)
Amps/Phase	21
Length	3.05 Metres
Width	1.25 Metres
Height	2.40 Metres
Starter	Star Delta

\* Includes spill chute

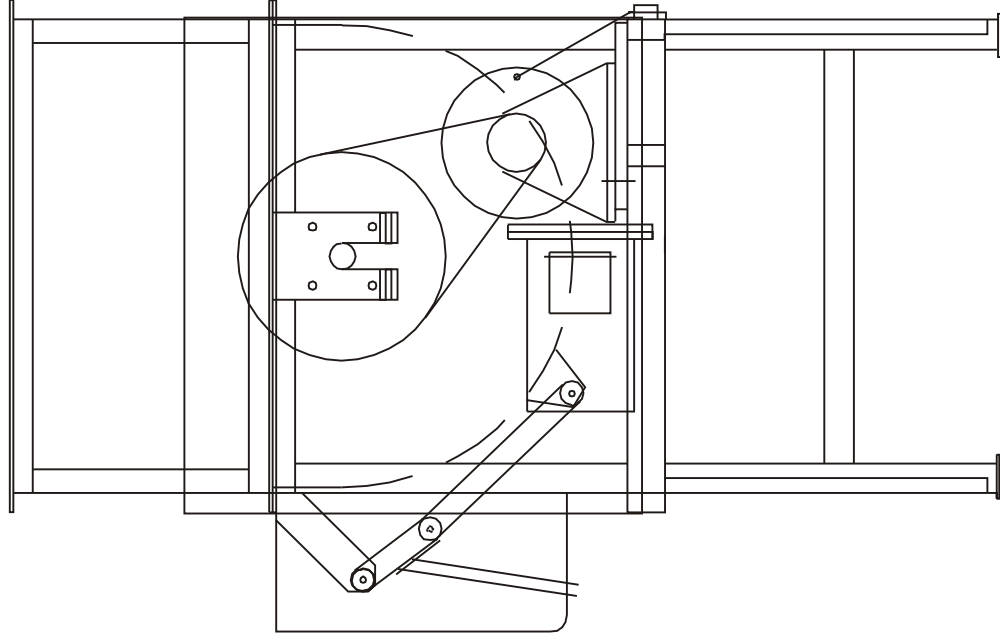

Side View

Please note all plans & specifications may change without further notice.