

Quality Solution For All Growers



Soil Conveyor

From ***K W Automation***



Flexible, able to be used almost anywhere, at any time.

Variety, all types of soils, wet or dry.

Mobile pneumatic rubber tyres for ease of movement.

Adjustable Legs adjust to 5 different height positions.

Easy loading made easy with small hopper.

Durable PVC cleated belt for conveyor.

Longevity low maintenance, easy to clean makes for a longer life.



Wheels shown

TIME SAVER AT A MINIMUM COST!!

Versatility was a major consideration in the design of our Conveyor.

The Soil Conveyor has the ability to either fill soil mixers or to empty soil into storage hoppers.

The 2 wheels are able to pivot 90° outwards from the frame giving the user more manoeuvrability and freedom in the setting up of the Conveyor.

1/2 H.P. (.37Kw) geared motor is used to drive the Conveyor. A resilient PVC cleated conveyor belt transfers up to 40 cubic metres of soil per hour.



Manufactured By:

K W Automation

PO Box 121, Old Bowling Green Rd
Palmwoods, Queensland 4555 Australia

Int (61) - (07) 5445 9549 - Fax (07) 5445 0499
Web Site: www.kwautomation.com.au

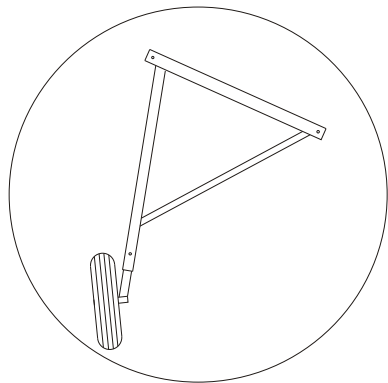
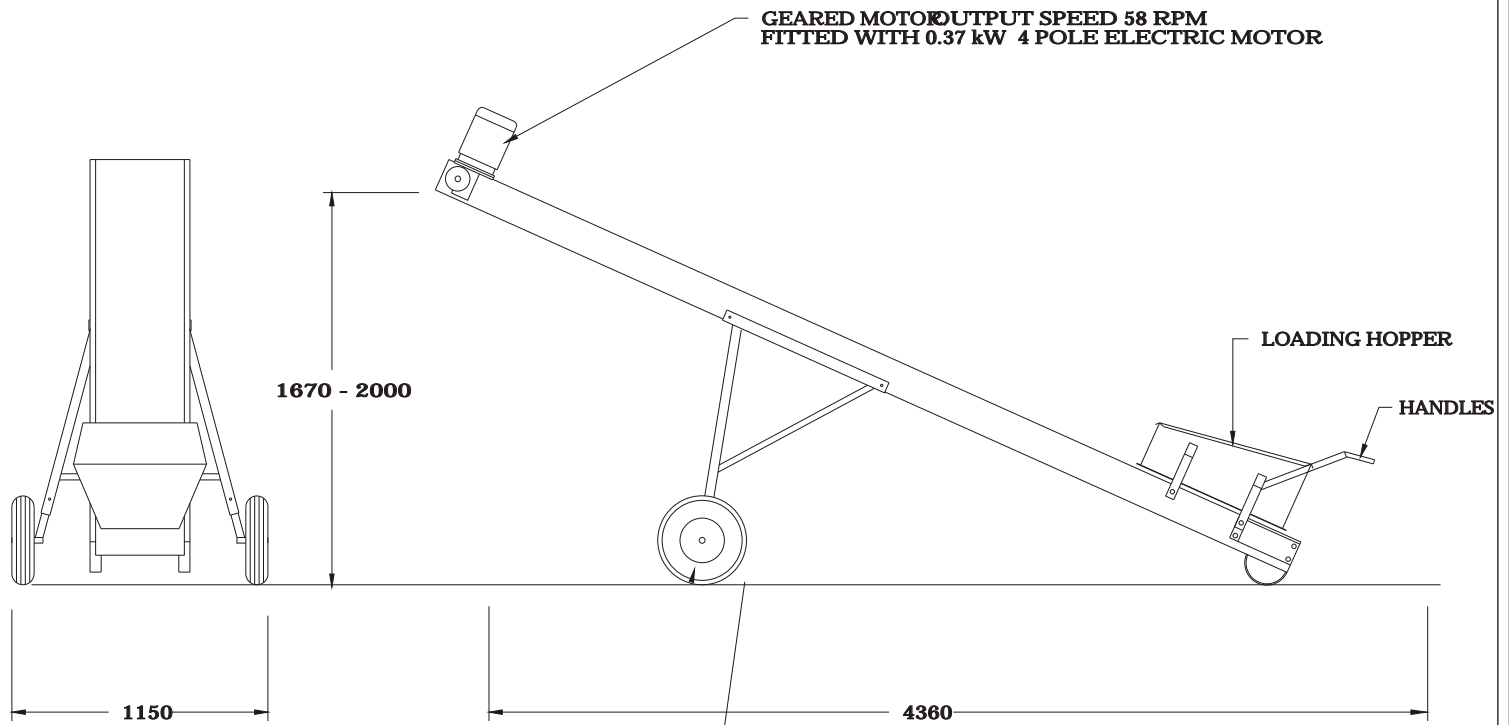

WHEELS CAN BE TURNED 90 FOR CIRCULAR MOVEMENT

Soil Conveyor	Specifications
Motor Capacity	1/2 H.P. (.37 Kw)
Power Supply Reqd	240V or 415V
Length	4.36 Metres
Width	1.150 Metres
Height(adjustable)	2.00 Metres(max.)
Conveying capacity	40 M ³ /Hour