

Quality Solution For All Growers



Pot & Bag Filler

From *K W Automation*



Pot & Bag Filling Machine With Storage Hopper.

- ▶ **1.5** Cubic Metre Soil Storage Hopper with sliding door to adjust soil flow.
- ▶ **Tough** long wearing 2 ply PVC belt situated underneath the hopper.
- ▶ **Height** adjustable table under belt for different size pots or bags.
- ▶ **Adjustable** soil flow for different size pots & bags.
- ▶ **Power** supply 240 or 415V.
- ▶ **Foot** pedal operated.
- ▶ **.56kw** geared electric motor drive.
- ▶ **Brake** clutch system for longer life.



Manufactured By:

K W Automation

PO Box 121, Old Bowling Green Rd
Palmwoods, Queensland 4555 Australia
Int (61) - (07) 5445 9549 - Fax (07) 5445 0499
Web Site: www.kwautomation.com.au

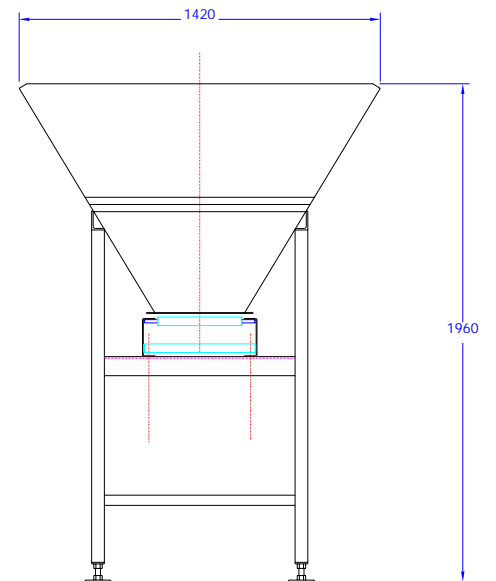
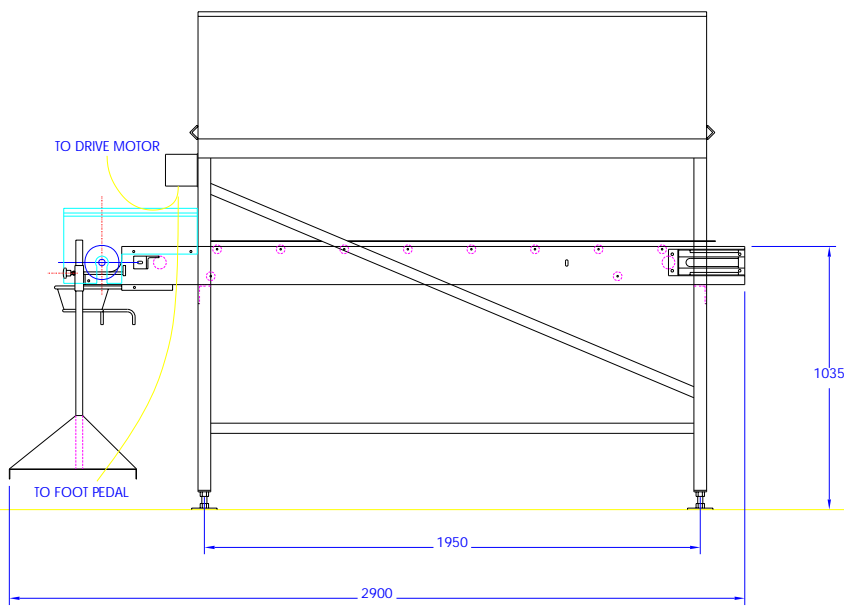
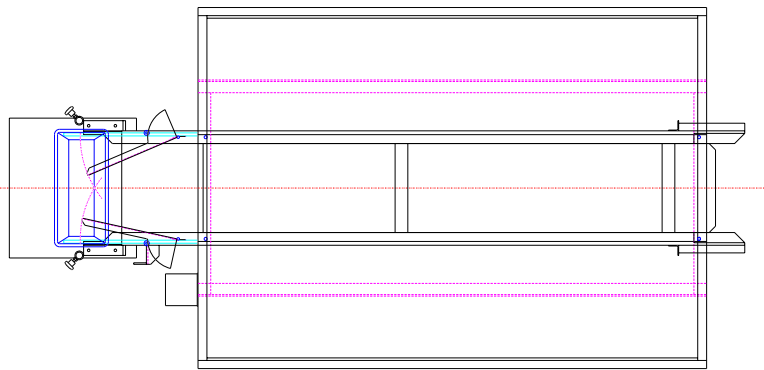

Specifications

Hopper Capacity	1.5 Cubic Metres
Motor Capacity	.55 Kw
Power Supply Req'd	240V or 415V
Length	2.900 Metres
Width	1.420 Metres
Height	1.960 Metres

Please note all plans & specifications may change without further notice.

K W AUTOMATION 27/04/05