

Quality Solution For All Growers .....



# Hot Spray Treatment

From ***K W Automation***



- ▶ **Dual** - capacity to dip in just hot water or a water/fungicide solution.
- ▶ **Compatible** - height adjustable legs.
- ▶ **Longevity** - stainless steel construction ensure a longer life.
- ▶ **Durable** - long-life poly tank.
- ▶ **Constant** - temperature through thermostatically controlled electronics.

Fruit is transported through the Hot Spray Conveyor by galvanised steel rollers mounted to a chain drive, for a duration of approx. 5 minutes.

Water is circulated throughout the heating system by centrifugal pump and electronically controlled using thermostats to keep solutions at a constant temperature as the grower requires.

The onboard time clock may be preset to automatically start the pump and heater.

The unit is necessary in stopping stem end rot and controlling Anthracnose. It also stops most fungal diseases while at the same time helping fruit to retain bright skin colour.

**Manufactured By:**



***K W Automation***

PO Box 121, Old Bowling Green Rd  
Palmwoods, Queensland 4555 Australia  
Int (61) - (07) 5445 9549 - Fax (07) 5445 0499  
Web Site: [www.kwautomation.com.au](http://www.kwautomation.com.au)

Hot Spray Specifications	
Tank Capacity	650 Litres
Capacity Geared Motors	1 X 0.18 HP (.18kW)
Heating System	25kW - Flow Through
Length	9.80 Metres
Width	2.0 Metres
Height	1.90 Metres
Capacity of Pump	50 litres/Minute
Power Usage	40A/Phase

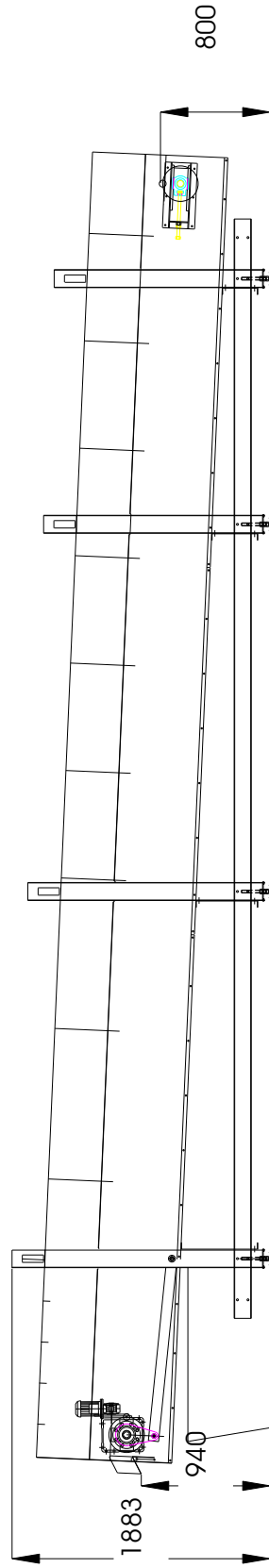
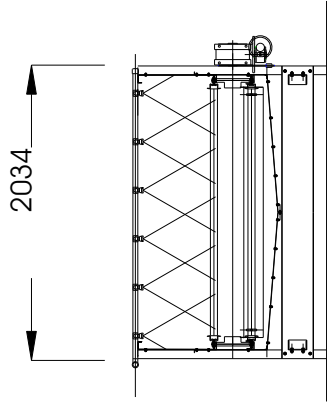
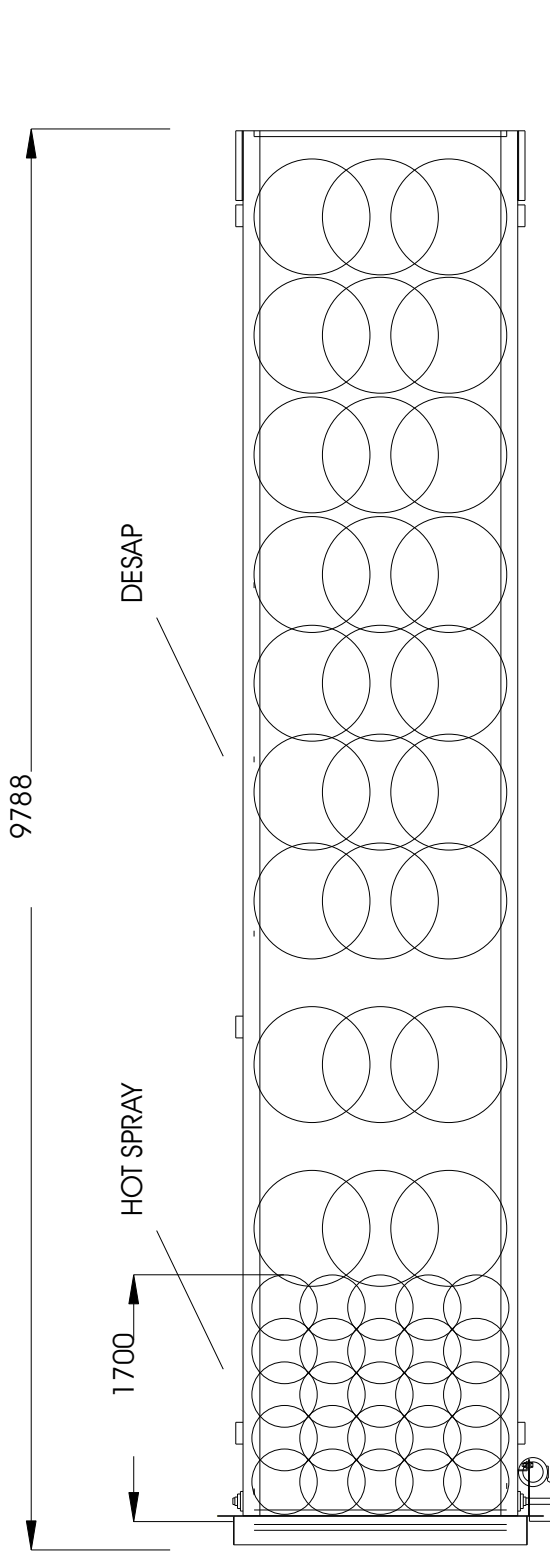

Please note all plans & specifications may change without further notice.