



# H35 Hand Seeder

From ***K W Automation***



"State-of-the-art technology allows accurate sowing."

- ▶ Sow seeds of all shapes and sizes (From as small as Petunia to as large as Watermelon).
- ▶ Seeds up to one row/sec. ( with any plug tray.)
- ▶ Eight sets of needle sizes are included with each machine.
- ▶ Quickly And Easily Change Seed Types And Trays.
- ▶ A vacuum collects seed in a removable glass jar for quick and easy change-over of seed varieties.
- ▶ Air Compressor optional.

State-of-the-art technology allows growers to accurately sow seeds of all shapes and sizes.

A vacuum is drawn through an array of interchangeable syringe needles to pick up the seeds.

The H35 now available in the Standard, Midi and Widebody model. The Midi and Widebody seeding the tray width ways and the Standard, length ways.

All standard trays can be used and changing from one tray to another is a simple procedure.

Double, triple and quadruple needles can be used to sow multiple seeds per cell (optional).



**Manufactured By:**

***K W Automation***

PO Box 121, Old Bowling Green Rd  
Palmwoods, Queensland 4555 Australia

Int (61) - (07) 5445 9549 - Fax (07) 5445 0499  
Web Site: [www.kwautomation.com.au](http://www.kwautomation.com.au)

H35 Std/Midi Seed-Air-Matic	Specifications
Production Speed	1 Row/Sec
Length - Std/Midi	1.200 Metres
Width - Std	.740 Metres
Width - Midi	.900 Metres
Height - Std/Midi	.420 Metres
Air Pressure Reqd	80PSI / 550KPA
Air Volume Reqd	10 CFM(free air delivery)
Suggested Min. Compressor Size	15 CFM
Max. Length Between Cell Centres	70mm
Max. Tray Width Std	365mm
Max. Tray Width Midi	515mm
Max. Tray Depth Std/Midi	175mm

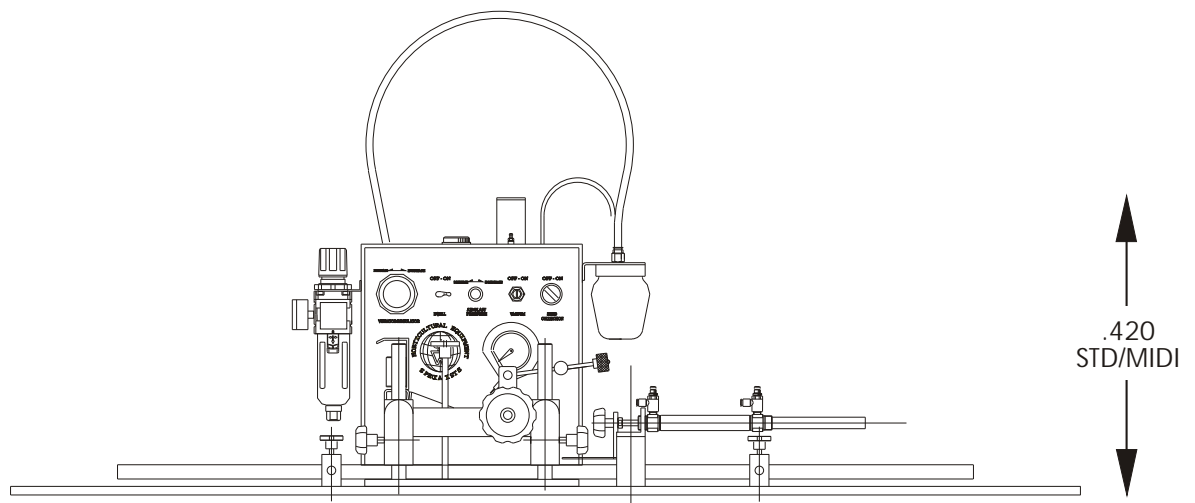
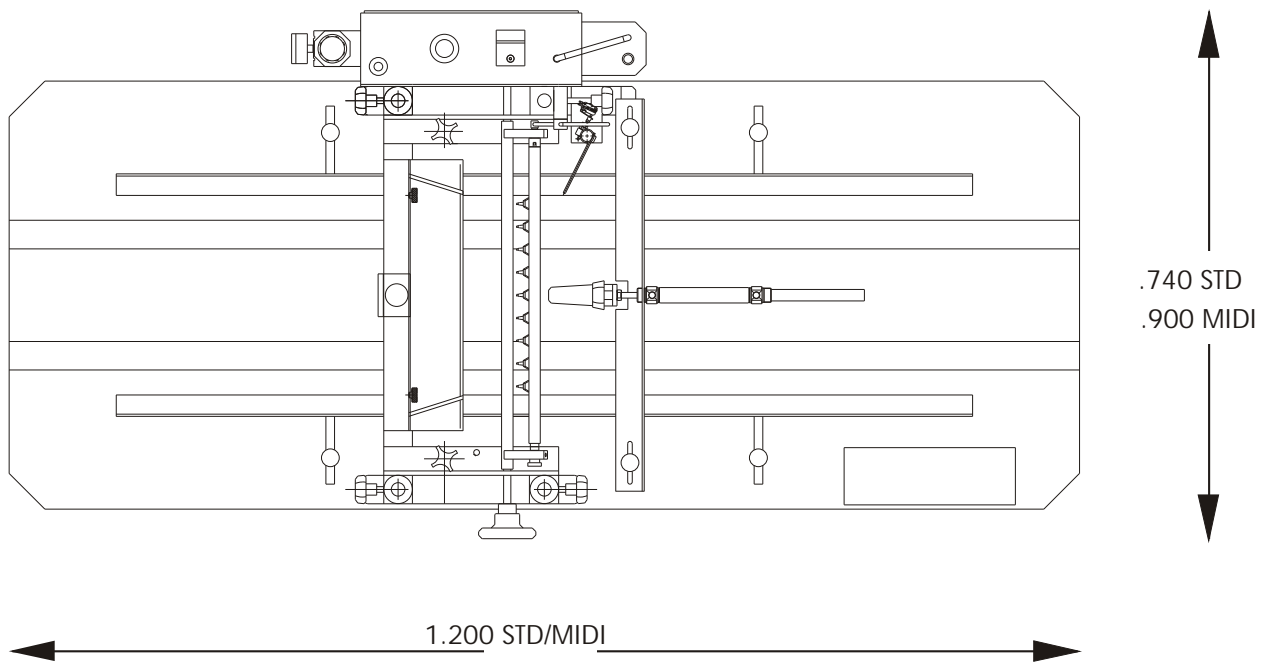

Please note all plans & specifications may change without further notice.