

Quality Solution For All Growers



EF Tray Filler

From *K W Automation*



Improve
Productivity

- ▶ **Capacity** - available in .75, 1.5, 3.0 cubic metre stainless steel storage hopper.
- ▶ **Electrical** variable speed drive for tray conveyor.
- ▶ **Choice** of single phase (240) or three phase (415V) power.
- ▶ **Compression** roller.
- ▶ **Quality** materials for durability and low maintenance.
- ▶ **Electric Eye** controlled soil box.
- ▶ **Height** adjustable 30 degree brush unit.

Increase Profits

- ▶ **Durable** P.V.C. belt for conveyor.
- ▶ **Automatic** soil return for excess soil.
- ▶ **Height** adjustable legs.
- ▶ **OPTIONAL:** Tray Dispenser. Soil Compaction system ideal for tubes, deep cell trays and pots.



SHOWN WITH OPTIONAL TRAY DISPENSER



Manufactured By:

K W Automation

PO Box 121, Old Bowling Green Rd
Palmwoods, Queensland 4555 Australia

Int (61) - (07) 5445 9549 - Fax (07) 5445 0499
Web Site: www.kwautomation.com.au

Ef75 Trayfiller	Specifications
Hopper Capacity	.75 Cu. Metres
Filling Capacity	
- trays/hour (600mm)	650
Length	4.2 Metres
Width	3.60 Metres
Height	1.450 Metres

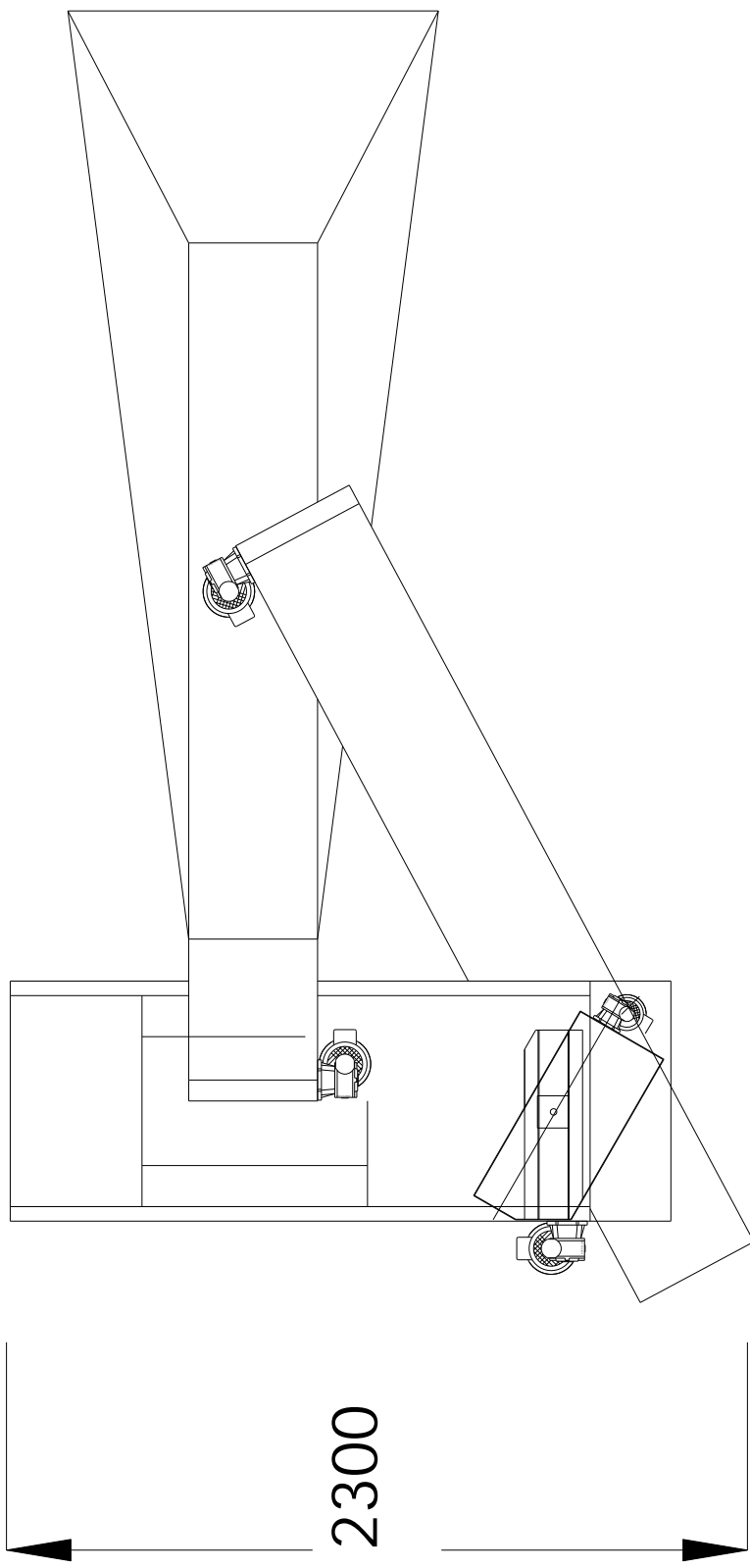
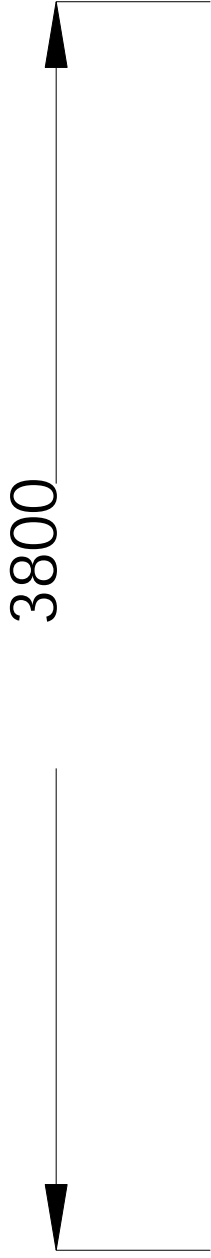

Please note all plans & specifications may change without further notice.